



Page 514
**Vertical Toggle Clamp
with Adapter**



Page 515
**Horizontal Toggle Clamp
with Adapter**



Page 516
**Adapter with Hole Pattern Ø 50 / 15
for Toggle Clamp**



Vertical Toggle Clamp with Adapter

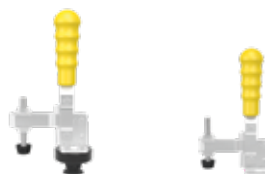
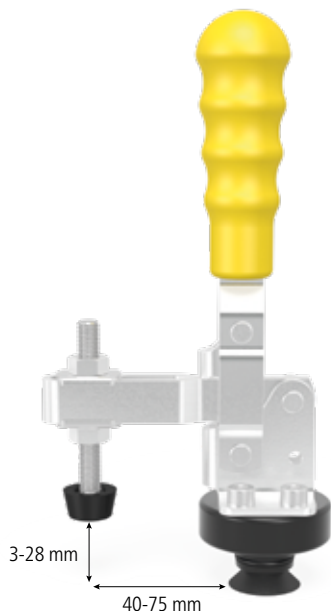

220705

009082

Description:

Vertical Toggle Clamp with Adapter, universally usable with 22 mm bore holes. It works most effectively in combination with the Universal Stop (Item No. 220420.N).

Further Quick-Change Clamps can be found on the Internet at www.siegmund.com

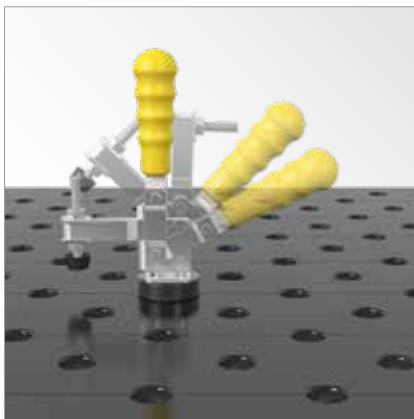

	Weight:	Item No.
Vertical Toggle Clamp with Adapter	0,64 kg	2-220705 ●
Vertical Toggle Clamp	0,39 kg	2-009082 ●

● = Item produced for stock; ○ = Item produced on order; Explanations see page 84

Horizontal Toggle Clamp with Adapter

Description:

Horizontal Toggle Clamp with Adapter, universally usable with 22 mm bore holes. It achieves maximum efficiency in combination with Universal Stop (Item No. 220420.N).

Further Quick-Change Clamps can be found on the Internet at www.siegmund.com

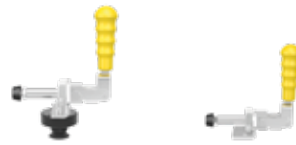
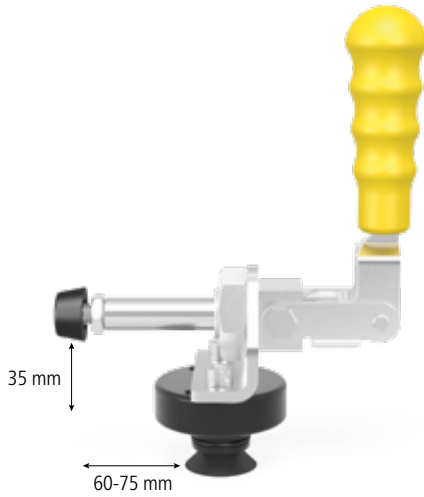

220710

009083

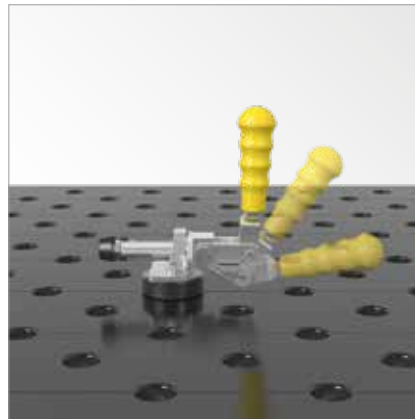

Horizontal Toggle Clamp with Adapter

Weight:

Item No.

0,64 kg

2-220710 ●

Horizontal Toggle Clamp

0,40 kg

2-009083 ●

● = Item produced for stock; ○ = Item produced on order; Explanations see page 84



Adapter with Hole Pattern

Description:

Adapter with Hole Pattern, can be used universally with 22 mm bore holes. The integrated O-ring provides the perfect fit.



220715



Height: (c)	Ø: (o)	MS: (d)	Weight:	Item No.
26 mm	50 mm	15 mm	0,22 kg	2-220715 ●

Adapter with Hole Pattern Ø 50 / 15
 - for Toggle Clamp
 - burnished

MS=Material thickness; ● = Item produced for stock; ○ = Item produced on order; Explanations see page 84

